

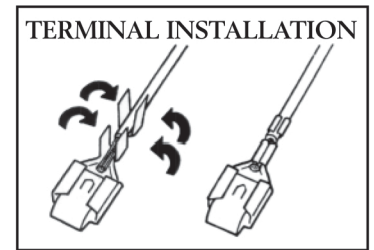

CRIMPING: We have supplied a connector and terminals to complete the wiring connection to the switch. Since most installers do not have the proper tool to complete the terminal connection, use needle nose pliers to crimp the terminals on the wire as shown in the drawing.
IMPORTANT: After the crimp is made, be sure to solder the connection.



CAUTION! The wiring harness connector supplied will leave exposed two ignition and two accessory terminals on the switch. When mounting the switch, make sure these terminals **WILL NOT** come in contact with any surrounding metal (ground).

In most installations this is not a problem, however if your application requires these terminals to be protected, call 1-800-292-1940 with your kit serial number. We will send out two, two gang connectors to insulate these terminals. Request part number CR-65.

WIRING: Engraved in the black plastic area on the base of the switch is abbreviated wording defining each spade terminal. Follow the chart below for the proper connections to the switch.

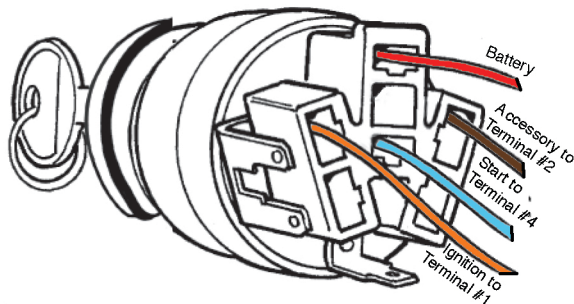

MOUNTING: It is important that the mounting nut be tightened as much as possible but it must be done without damaging the mounting nut itself. If you must use a hand tool to accomplish this, install one of the colored "O" rings that will not be used after final assembly or wrap the nut with three layers of masking tape. Continue tightening the nut. Remove the tape or and install the final colored O-ring. We recommend keeping the un-used O-rings in case the switch needs re-tightening at a later date.

SWITCH WORDING	USED FOR	CONNECTION DEFINITION	Access 24/7, Express, Bare Bonz I & II, AP-97, CP-94, DM-16 Wire Colors	CP-92 & Older Colors
BAT	Battery Feed	Requires a battery hot all the time wire.	Red	Yellow
IGN	Ignition Feed	This wire is hot with the key in the run & crank position.	Orange	Orange
ACC	Accessory Feed	This wire is hot with the key in the accessory and run position. Terminal is inactive in the crank position.	Brown	Red
ST	Starter	This wire hot with the key in the crank position only.	Light Blue	Light Blue
Un-Marked	Bulb Test	Normally not used in an aftermarket application. Terminal is grounded with the key in the crank position. Switch must be properly grounded for this terminal to function.	N/A	N/A